

Side gusseted bag making machine SFB 8E -L

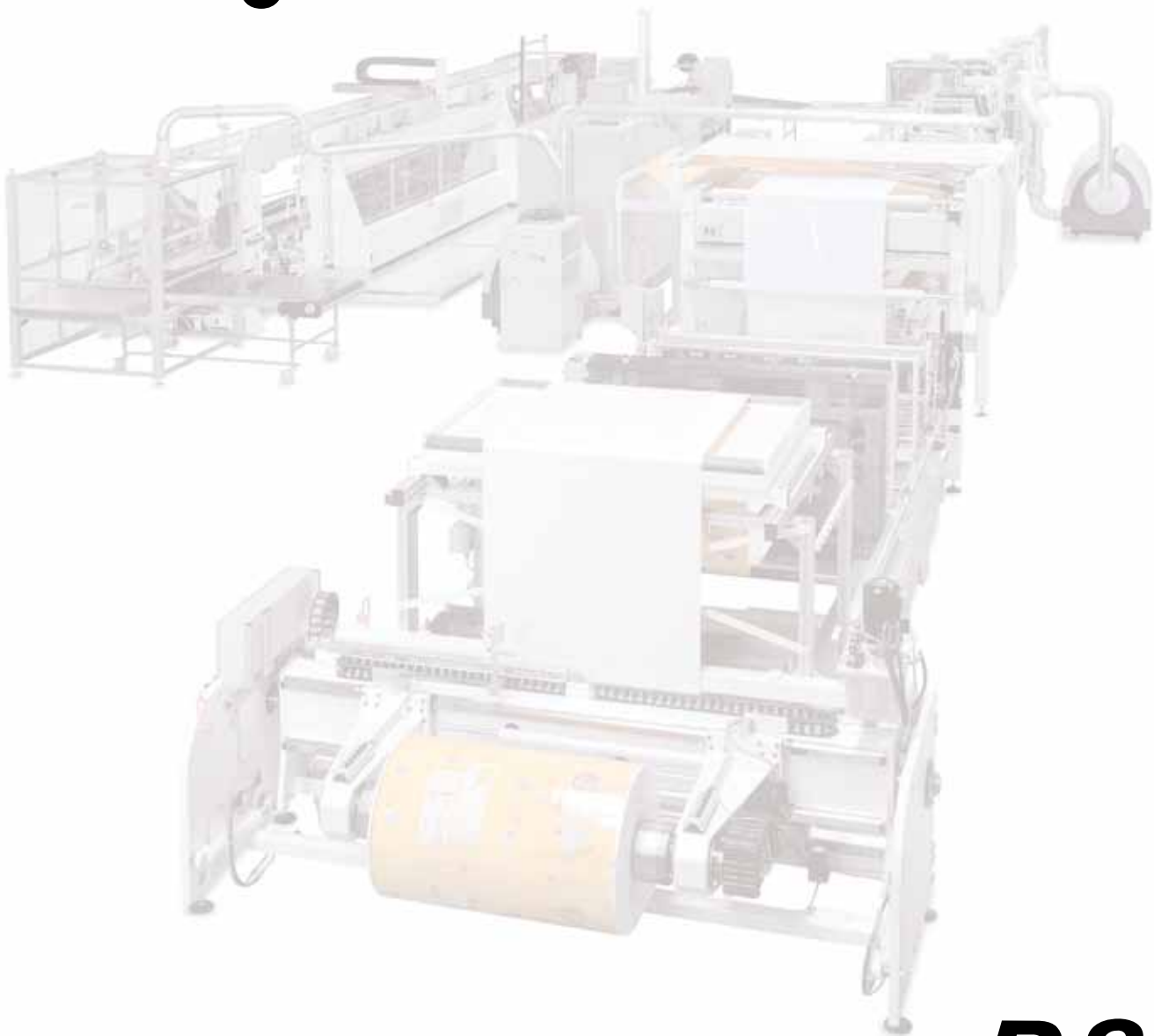

→ Longitudinal production of bags.
Faster. Safer. More efficient.

B&B
PACKAGING SOLUTIONS
MAF

→ Side gusseted bag making machine SFB 8E -L



Side gusseted bag making machine SFB 8E -L

The B&B-MAF side gusseted bag making machine SFB 8E -L serves the production of side gusseted bags working from one-film-roll in longitudinal machine direction.

Composite film materials, such as PET/PE, with a film strength from 90 µm to 200 µm and PE/PE composites with a film strength of 150 µm to 200 µm can be converted.

Bags can be produced at a speed of up to 70 cycles/min in one or dual lane production process.

Technical data	1-up	2-up
Max. roll diameter:	1,200 mm	1,200 mm
Max. roll width:	1,600 mm	1,600 mm
Max. bag length:	1,000 mm	1,000 mm
Min. bag length:	200 mm	200 mm
Max. bag width:	500 mm	270 mm
Min. bag width:	100 mm	100 mm
Max. side gusset (opened side gusset):	200 mm	200 mm
Min. side gusset (opened side gusset):	60 mm	60 mm
Max. zipper length:	400 mm	240 mm

Production performance	1-up / min	2-up / min
Performance < 500 mm length:	ca. 70 cycles ≈ 70 bags	ca. 70 cycles ≈ 140 bags
Performance > 500 mm length:	ca. 30 - 50 cycles ≈ 30 - 50 bags	ca. 30 - 50 cycles ≈ 60 - 100 bags

Bag variations

- Side gusseted bags
- Side gusseted bags with reclosure
 - Top/front zipper (PTC)
 - Lateral zipper (PTC)
 - Front slider
 - Hooded slider
- Side gusseted bags with bottom fold
- Side gusseted bags with various handles

Details



Bottom fold

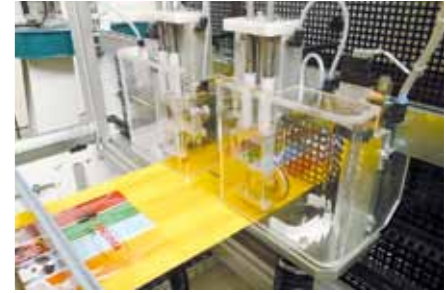

Snippet removal for rounded corners

Modular design

With the modular design of our machines, customer-specific extensions for punches, perforation, additional weldings, patches, bottom-folding unit etc. can be implemented easily at any time.

This enables your company to react quickly to the changing demands of the market.



Zipper unit



2-up folding unit

Sample products



Automatic format adjustment



→ Side gusseted bag making machine SFB 8E -L

Layout SFB 8E -L

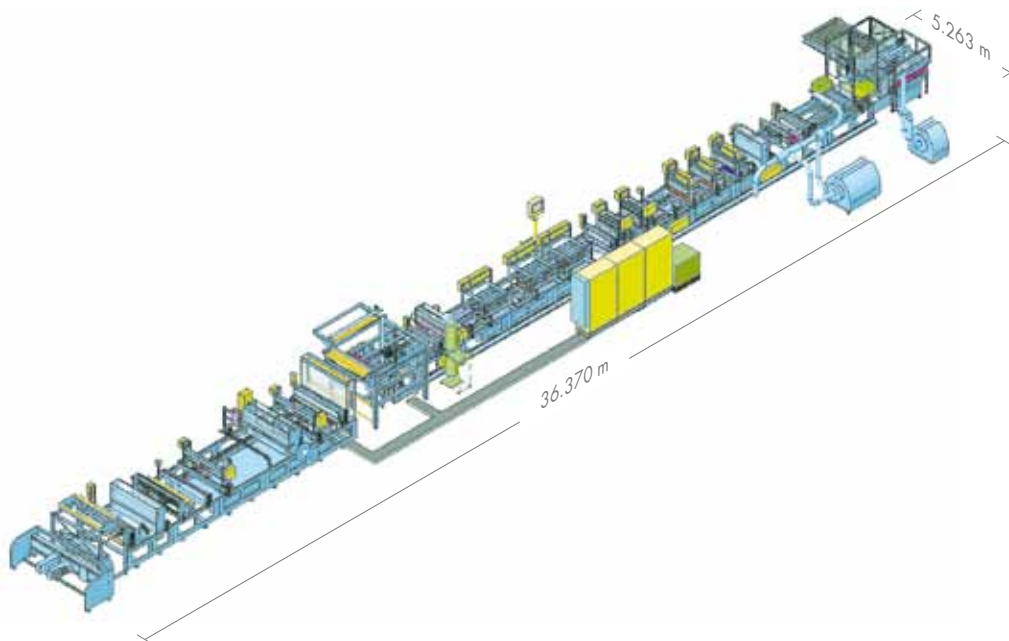

Perfect Packaging

As an owner-managed medium-sized business, we have been an innovative manufacturer of bag making and packaging machines for more than 50 years.

High reliability, long service life, perfect integration capacities, flexibility and outstanding product efficiency are closely connected to our story of success.

Packaging or bag making machines, standard or individual solutions – our highly qualified engineers and specialists know how to implement every customer wish with best precision and excellent service.

Do you have any questions or are you looking for a matching packaging solution for your products?

We will gladly inform you on the options. Feel free to contact us.

→ B&B-MAF GmbH & Co. KG
Kupferstraße 18 · 48496 Hopsten/Germany
Phone +49 5458 7930
Telefax +49 5458 79350
mail@bub-maf.de
www.bub-maf.de

→ B&B-MAF LP
2120 East Deerfield Avenue
Green Bay, WI 54173 USA
Phone +1 920 469 9648
mail@bub-maf.com
www.bub-maf.com

B&B
PACKAGING SOLUTIONS
MAF